

# Bayonne Bridge—Design and Construction Features

by Joseph LoBuono and Chester Werts, HDR



Traffic relocated to the new upper level of the Bayonne Bridge using the northbound approach structure. All Photos and Figures: HDR.

On February 20, 2017, one lane of traffic in each direction was relocated to the new upper level of the Bayonne Bridge. With the traffic relocated to what will become the northbound structures, demolition of the existing arch floor commenced. The Port Authority of New York & New Jersey planned the construction of the Bayonne Bridge Navigational Clearance Program to coincide with the expansion of the Panama Canal, so that the new generation of larger container vessels had sufficient clearance to pass under the bridge and access the Ports of Elizabeth and Newark. Accordingly, every effort was made to expedite the elimination of the existing arch floor of the Bayonne Bridge, thus increasing the air draft from 151 to 215 ft.

For this to occur, both the arch structure and the northbound approach structures had to be ready to transfer traffic onto the elevated roadway. This article highlights some of the design features used to expedite the construction schedule. These include using combined precast concrete pier caps, a pipe strut to brace the taller Type 1 piers

during construction, split superstructure pier segments, and balanced-cantilever construction at expansion joints.

## Approach Substructure

The geometry of the precast concrete columns and pier caps was created to complement the original architecture of the 1931 Bayonne Bridge piers, while providing an efficient structural section that could be cast, transported, and erected as expeditiously as possible. Approach-structure piers can be divided into three groups: Type 2 single piers used closer to the abutments, where the wider roadways shift the box-girders apart; short Type 1 combined piers, where the side-by-side structures transition to the typical

roadway width; and tall Type 1 combined piers, where intermediate haunched cross beams connect the tall, slender columns at approximately midheight.

Type 1 combined precast concrete pier caps were effectively used to accelerate the construction of the substructure in advance of the segmental superstructure construction. The three-piece precast concrete pier caps are supported by the flared-pier capital segment that forms the base of the pier cap arch when complete. Precast concrete pier segments are constructed similarly to the precast concrete segmental columns, with both vertical and horizontal post-tensioning (PT) bars temporarily clamping the segments together and providing the required compression on the epoxy adhesive joints until the final multi-strand tendons are stressed. Transverse horizontal multi-strand tendons provide capacity for the cantilevered pier cap segments, and looped column multi-strand tendons are stressed at the top of the pier cap. Precast concrete segmental construction of the pier caps expedited the construction schedule and was exceptionally conducive to the staged construction of the northbound and southbound roadways. Each pier cap could be quickly constructed independently of the adjacent cap. When the two side-by-side structures are completed, the cast-in-place reinforced concrete closure will be placed and the two pier caps will then be post-tensioned together forming a framed two-column pier.

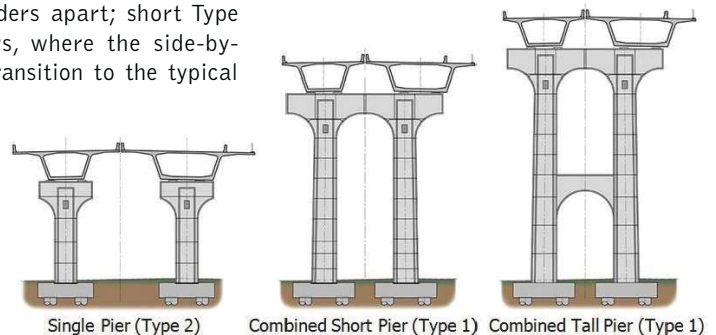

Precast concrete pier types.

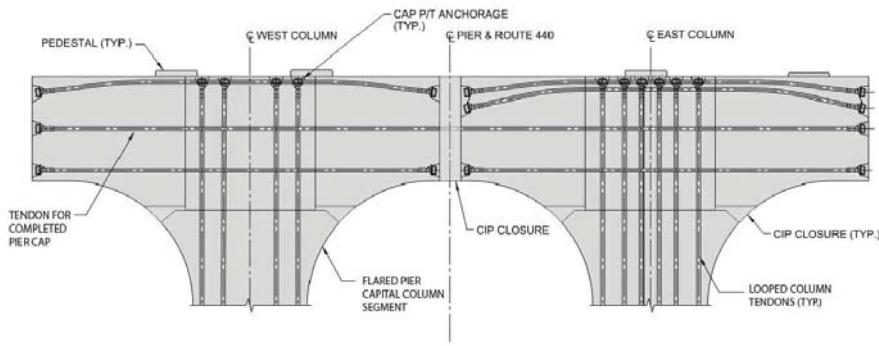

ELEVATION VIEW

Combined pier post-tensioning for the Bayonne Bridge Type 1 piers.

For the Type 2 single piers, the centerline of the box girder is concentric to the centerline of the column on both the northbound (east) and southbound (west) structures. But the Type 1 combined piers are laid out such that the centerline of northbound structure's box girder is eccentric to the associated Type 1 column section. This 7.7-ft eccentricity is due to the additional width of the northbound structure, which accommodates a 12-ft-wide shared-use path and an additional pedestrian barrier. There is also the constraint on the column location due to the existing structure's exterior girder.

To accelerate delivery of the Bayonne Bridge project, the decision was made to maintain all construction within the existing right-of-way and obtain underground easements where footings went outside the right-of-way lines. With this strategy, the new facility did not require the acquisition of property, so environmental documents were prepared and approved as an environmental assessment rather than an environmental impact statement. This saved a minimum of three years in the design process.

The single most important schedule enhancement was the redesign of the as-bid

construction sequence that required the partial construction of the southbound substructure to brace the northbound column. The as-bid contract drawings also included a construction sequence for the tall Type 1 piers that used cast-in-place construction for both the southbound and northbound columns up to the top elevation of the intermediate cast-in-place concrete cross beam beneath the existing structure, which remained in place during northbound construction. This intermediate cross beam provided stability to the northbound piers and reduced the overall lateral movements in the columns during construction, and would continue to do so throughout the life of the structure.

After the construction contract was awarded, an effort was made to develop a modified construction sequence that would expedite the construction schedule for the substructure and therefore for all the approach structures. One modification was constructing both the northbound and southbound piers to be fully independent precast concrete structures. Another modification was using temporary steel pipe struts under the east hammerhead cantilevers of the northbound pier caps



Erection of precast concrete column segment.

Column location constrained by existing edge girder.

to mitigate transverse overturning moments and transverse deflections during construction. The pipe strut concept eliminated the need to build the southbound piers and cross beams to brace the northbound columns.

There were many design and construction challenges that accompanied this bold move to temporarily support the eccentric northbound superstructure with struts. Design challenges included the redesign of the tall single columns, the design of the steel pipe strut connections at the underside of the pier cap, and the design of a new steel space truss with precast concrete cladding to replace the cast-in-place concrete cross beam. Challenges during construction included properly engaging the pipe strut load path and predicting and monitoring both the forces in the struts and deflections of the piers. The change to a fully precast concrete pier, as well as the additional change of the cast-in-place crossbeam to a steel space truss, accelerated construction by using all prefabricated components.



Temporary pipe strut bracing a northbound Type 1 pier.

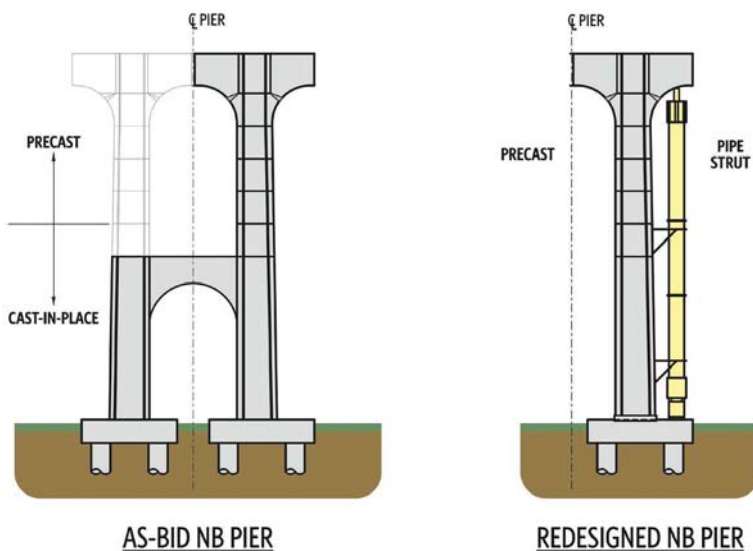

As-bid and redesigned Type I pier during construction of northbound superstructure.





Rendering of twin side-by-side precast concrete box girders and completed pier. The northbound segment is wider to accommodate a 12-ft-wide shared-use path and an additional pedestrian barrier.

## Approach Superstructure

A total of 1079 precast concrete box-girder segments are being erected using a balanced-cantilever method to construct more than two miles of segmental approach roadway. The precast concrete segments for the twin structures range in width from 39 ft 3 in. for the typical southbound segment to 64 ft 10 in. at northbound abutment N15, with segments weighing up to nearly 112 tons. Constant-depth girders having spans of up to 210 ft and haunched girders with spans of up to 272 ft are used for the approach structures.

Split-pier segments are used on the balanced-cantilever pier tables at the haunched piers to maintain the exclusive use of precast concrete construction at the piers and to expedite the construction erection schedule. Haunched girders are 14 ft deep at the pier, and with the weight of the diaphragms it was not possible to keep the total weight of the segment below 112 tons. The weight limit was controlled by the maximum load of the transported segment and trailer that could cross the existing arch and the overall length of the trailer that would have to navigate the residential neighborhoods adjacent to the bridge. Cast-in-place diaphragms were also considered during the design phase; however, the precast concrete split-pier segment was chosen because it would allow faster erection and eliminate the potential for construction delays caused by the placement of diaphragm reinforcement or concrete. The diaphragm was then effectively split in half, with two parallel walls providing the load path to the bearings.

Balanced-cantilever construction was consistently used at all pier locations, including the expansion-joint piers, which further expedited the construction schedule and eliminated the need for end-span falsework at high-level expansion joints. Approach structures ranging in length from 2377 to 2929 ft required multiple



Gantry erection of cantilever at expansion pier and split-pier segment erection by crane.

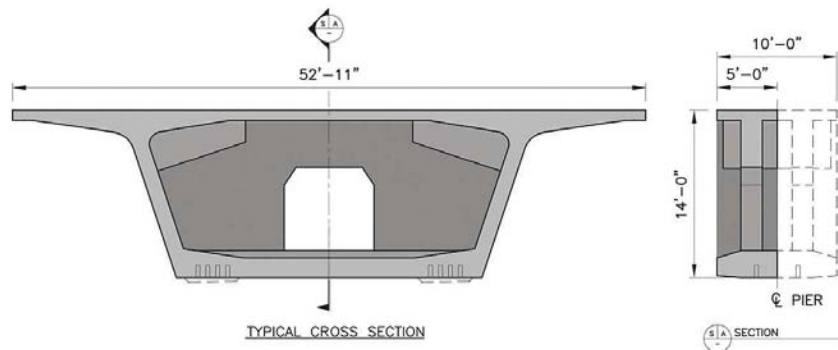

Precast concrete split-pier segments for balanced-cantilever pier tables at haunched piers.

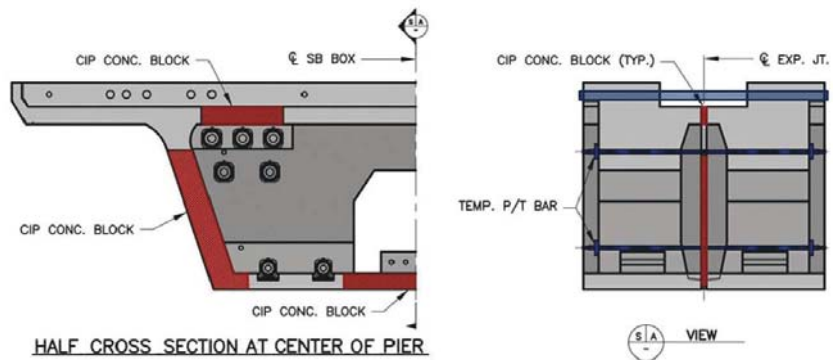

Precast concrete expansion-joint segment details (as-bid concept).

expansion joints to accommodate both the long-term concrete movements and the cyclic thermal and service movements of the structure. The design team located the expansion joints at the piers and adopted a construction sequence that would accommodate a similar balanced-cantilever construction sequence as the typical cantilevers. To do this, the expansion-joint segments were spaced a few inches apart and temporary cast-in-place concrete blocks were cast between the segments, which were then post-tensioned together using temporary PT bars.

Once the two expansion segments were post-tensioned together, the construction sequence was similar to the split-pier segments, with the adjacent up-station and down-station segments forming the four-segment pier table, and an additional three to four segments erected in cantilever on either side. After the next two spans were completed, the contractor could then go back, release

the bearing restraints, remove the temporary PT bars, and cut the temporary cantilever multistrand tendons one at a time, thereby releasing the adjacent expansion segments.

## Conclusion

Maximizing the use of precast concrete and prefabricated design features, as well as eliminating the need to build a portion of the southbound substructure under the existing structure using cast-in-place concrete, streamlined the construction sequence and reduced the overall construction schedule. **A**

*Joseph LoBuono is vice president and major bridge technical director with HDR in Newark, N.J., and Chester Werts is a senior bridge engineer with HDR in Olympia, Wash.*

## EDITOR'S NOTE

*Another article about the Bayonne Bridge project is included in this issue on page 20.*